

1/2-13UNC-2B THD X 1.00 DEEP  
4-HOLES EQUALLY SPACED  
ON A 7.250 DIA. B.C.

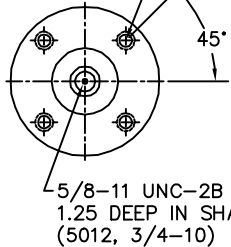

5/8-11 UNC-2B THD'S  
1.25 DEEP IN SHAFT END  
(5012, 3/4-10)

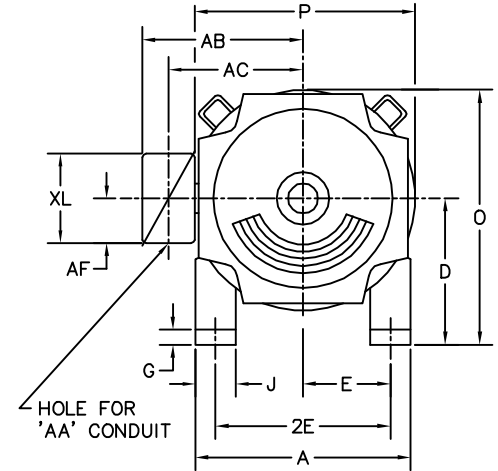
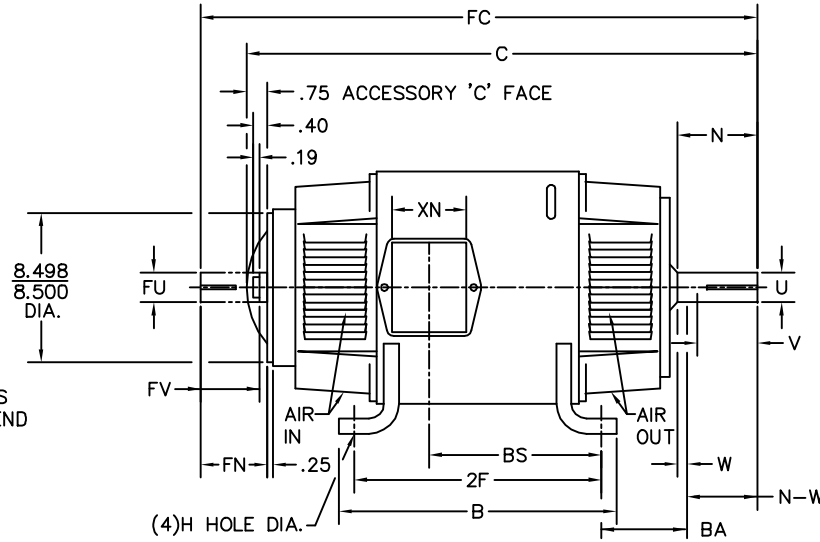
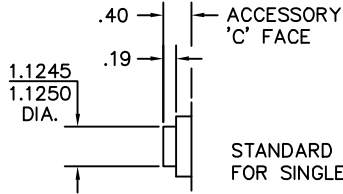

FRAME	FOOT MOUNTING						D.E. SHAFT EXTENSION					DRIVE KEY		ACC SHAFT EXTENSION			ACC KEY		FRAME						
	BA	E	2F	G	H	J	N	N-W	U	V	W	KEY-SQ.	KEY-LONG	FN	FU	FV	KEY-SQ.	KEY-LONG	A	B	C	FC	D	O	P
504AT	8.50	10.00	16.00	1.18	1.188	4.50	6.76	6.57	3.250	6.32 <sup>3</sup>	.19	.750	5.25	5.95	2.875	5.70	.750	5.00	24.88	18.88	45.75	51.00	12.50 <sup>2</sup>	24.91	24.81
506AT	8.50	10.00	20.00	1.18	1.188	4.50	6.76	6.57	3.250	6.32 <sup>3</sup>	.19	.750	5.25	5.95	2.875	5.70	.750	5.00	24.88	22.88	49.75	55.00	12.50 <sup>2</sup>	24.91	24.81
508AT	8.50	10.00	25.00	1.18	1.188	4.50	6.76	6.57	3.250	6.32 <sup>3</sup>	.19	.750	5.25	5.95	2.875	5.70	.750	5.00	24.88	27.88	54.75	60.00	12.50 <sup>2</sup>	24.91	24.81
5010AT	8.50	10.00	32.00	1.18	1.188	4.50	6.76	6.57	3.250	6.32 <sup>3</sup>	.19	.750	5.25	5.95	2.875	5.70	.750	5.00	24.88	34.88	61.75	67.00	12.50 <sup>2</sup>	24.91	24.81
5011AT	8.50	10.00	36.00	1.18	1.188	4.50	6.76	6.57	3.375	6.32 <sup>3</sup>	.19	.875	5.25	5.95	2.875	5.70	.750	5.00	24.88	38.88	65.75	71.00	12.50 <sup>2</sup>	24.91	24.81
5012AT	8.50	10.00	43.00	1.18	1.188	4.50	7.06	6.87	4.250	6.62 <sup>3</sup>	.19	1.000	5.25	5.95	2.875	5.70	1.000	5.00	24.88	45.88	73.75	79.75	12.50 <sup>2</sup>	24.91	24.91

FRAME	CONDUIT BOX							ARM APPROX. LBS.FT. <sup>2</sup>	APPROXIMATE WEIGHT
	AA	AB	AC	AF	BS	XL	XN		
504AT	3	20.65	16.81	2.62	13.25	11.63	7.76	79.10	1910 <sup>5</sup>
506AT	3	20.65	16.81	2.62	17.25	11.63	7.76	98.76	2290 <sup>5</sup>
508AT	3	20.65	16.81	2.62	22.25	11.63	7.76	121.87	2820 <sup>5</sup>
5010AT	4 <sup>4</sup>	21.20	16.81	2.84	30.12	13.40	13.50	156	3450 <sup>5</sup>
5011AT	4 <sup>4</sup>	21.20	16.81	2.84	34.12	13.40	13.50	161	3810 <sup>5</sup>
5012AT	4 <sup>4</sup>	21.20	17.19	2.84	41.12	13.40	13.50	170	4887 <sup>5</sup>

- 1) SHAFT DIAMETERS TO 1.500 TOLERANCE +.0000 -.0005  
SHAFT DIAMETERS ABOVE 1.500 TOLERANCE +.0000 -.0010  
SHAFT DIAMETERS TO 1.625 RUNOUT .002 T.I.R. MAX.  
SHAFT DIAMETERS ABOVE 1.625 RUNOUT .003 T.I.R. MAX.
- 2) 'D' DIMENSION TOLERANCE +.000 - .060.
- 3) 'V' DIMENSION IS MAX. HUB LENGTH ON SHAFT
- 4) THERE ARE TWO HOLES FOR 4" CONDUIT, SECOND HOLE IS 6" TOWARD DRIVE END.
- 5) TOTAL WEIGHT OF MOTOR.
- 6) ALL DIMENSIONS NOT NOTED ARE NOMINAL DIMENSIONS CONSULT FACTORY FOR TOLERANCES.

FOR F1 OR F2 CONDUIT BOX LOCATION SEE SALES ORDER

CUSTOMER IS RESPONSIBLE FOR DETERMINING THAT MOTOR PERFORMANCE IS SUITABLE IN THE APPLICATION.

REV. DESC: CHG (5011)U DIM TO 3.375, KEY-SQ TO .875		REV. LTR: D BY: MBT		REVISED: 07:59:01 04/22/2003		TDR: 299170	
Ω-LL8		FILE: CHB00001040		REF: 877-3			
		MTL: -					

BALDOR ELECTRIC Co.

DIM SHEET: 504-5012AT,DPFG